

Kee Step[®]

SAFETY AT THE HIGHEST LEVEL

Bridge Assembly Instructions – SAP-B-4-NS



1. BASIC SAFETY INSTRUCTIONS

Basic safety instructions for the safe handling of the Kee Step® Step Over system can be found here.

DANGER TO LIFE!

It is imperative that you follow these safety instructions to avoid endangering your life and safety.



Possible Danger	Prevention Measures
<p>DANGER TO LIFE! There is a risk of the construction personnel falling during assembly or when carrying out repairs. Explanation: Inadequate or insufficient safety measures or errors during the assembly of the Step Over system can lead to falls resulting in severe/fatal injuries.</p>	<ul style="list-style-type: none"> • The Step Over system is only to be assembled as specified in the assembly instructions. • After assembly or after carrying out repairs, check all structural parts and connecting components to make sure that they are located correctly. • Do not install the platform on any surfaces, either internal or external, that are damaged.
<p>DANGER TO LIFE! There is a risk of the Step Over system failing if the installation site is unsatisfactory. Explanation: A non-approved roof surface can result in The Walkway system sliding and failing.</p>	<ul style="list-style-type: none"> • Follow the detailed information on the installation sites for the Step Over system in the assembly instructions. • The roof surface must always be of the prescribed quality and load-bearing capacity. • The prescribed measures must always be complied with.
<p>DANGER TO LIFE! There is a risk of people falling due to failure to carry out maintenance work on the Step Over System. Explanation: Defects or damage can impair the function of the Walkway system therefore the system may possibly not be guaranteed in the event of an emergency.</p>	<ul style="list-style-type: none"> • If you have to carry out repairs on the roof or any plant always carry out a visual check on the Step Over system and the roof area beforehand for damage. • Any parts that are found to be damaged, must always be replaced before any work is started. Only then is it permitted to start the actual work on the roof.
<p>DANGER TO LIFE! There is a risk of people falling due to attaching Personal Protection Equipment to a Step Over system. Explanation: The Walkway system must never be used to attach P.P.E. to as an anchor for abseiling or similar work.</p>	<ul style="list-style-type: none"> • The Step Over system is a stand alone, maintenance Walkway system and should always be treated as such. Under no circumstances should the system be used as a "man anchor" or as a connection for P.P.E.

2

2. INSTRUCTION

Basic safety instructions for the safe handling of the Kee Step® Step Over system can be found in the Kee Step Step Over Instructions for use Manual.





Start Up Tools

Minimum 2 User Recommended for Assembly



Level



Socket Wrench



Tape Measure



Full Set Imperial Allen Keys



Rubber Mallet



Hex Key Socket Screw Sized 5/16" AF



Impact Driver



Torque Wrench 8 ft-lb - 45 ft-lb



5/16" Socket Driver



Safety Gloves



Checking the Bridge Components

ID 1



10-8 Tee

ID 2



TREAD - (WW100040)

ID 3

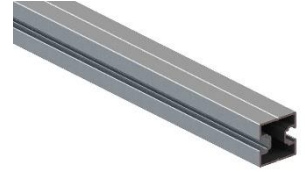

EXTRUSION - (WW4040030)

ID 4



1 - 1/2" ALUM. U BRACKET

ID 5



CAP - (WW16258CP)

ID 6



3/8" FENDER WASHER

ID 7



WW6.3 X 25MM SCREW

ID 8 & 9



G150GS12GA - TUBE

Table 1 - Components Table

Use Table 1 to identify Parts in Assembly instruction.

Table 1

ID	FITTING DETAIL	QTY
1	10-8	4
2	WW100040	3
3	WW4040030 @ 29 3/8"	2
4	1-1/2" ALUM. U BRK	4
5	WW16258CP	4
6	3/8 FENDER WASHER	8
7	WW6.3 X 25MM SCREW	14
8	1-1/2" TUBE @ 29 1/4"	6
9	1-1/2" TUBE @ 26"	2

General Description

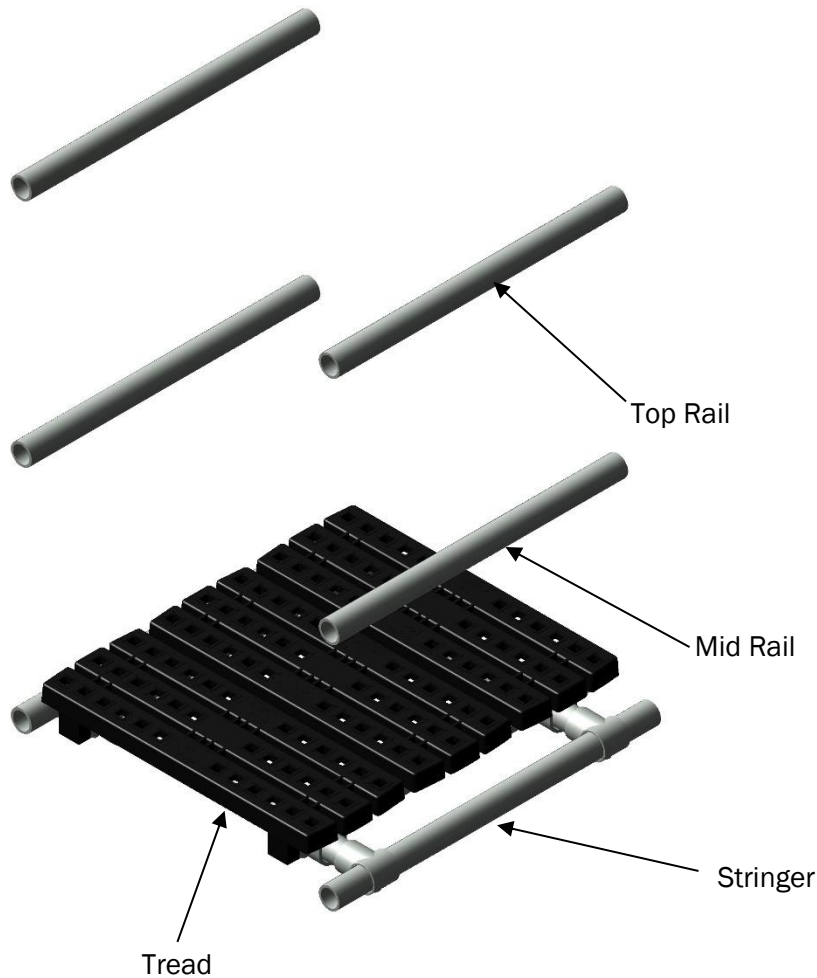



Assembling the Bridge

Assembly 1 – Attaching Caps to Extrusions

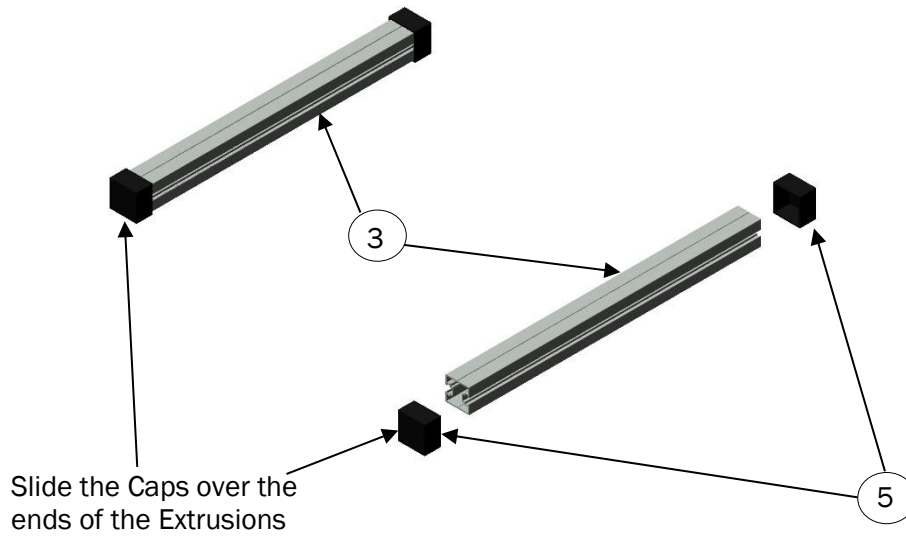

Assembly 2 – Connect treads to Extrusion

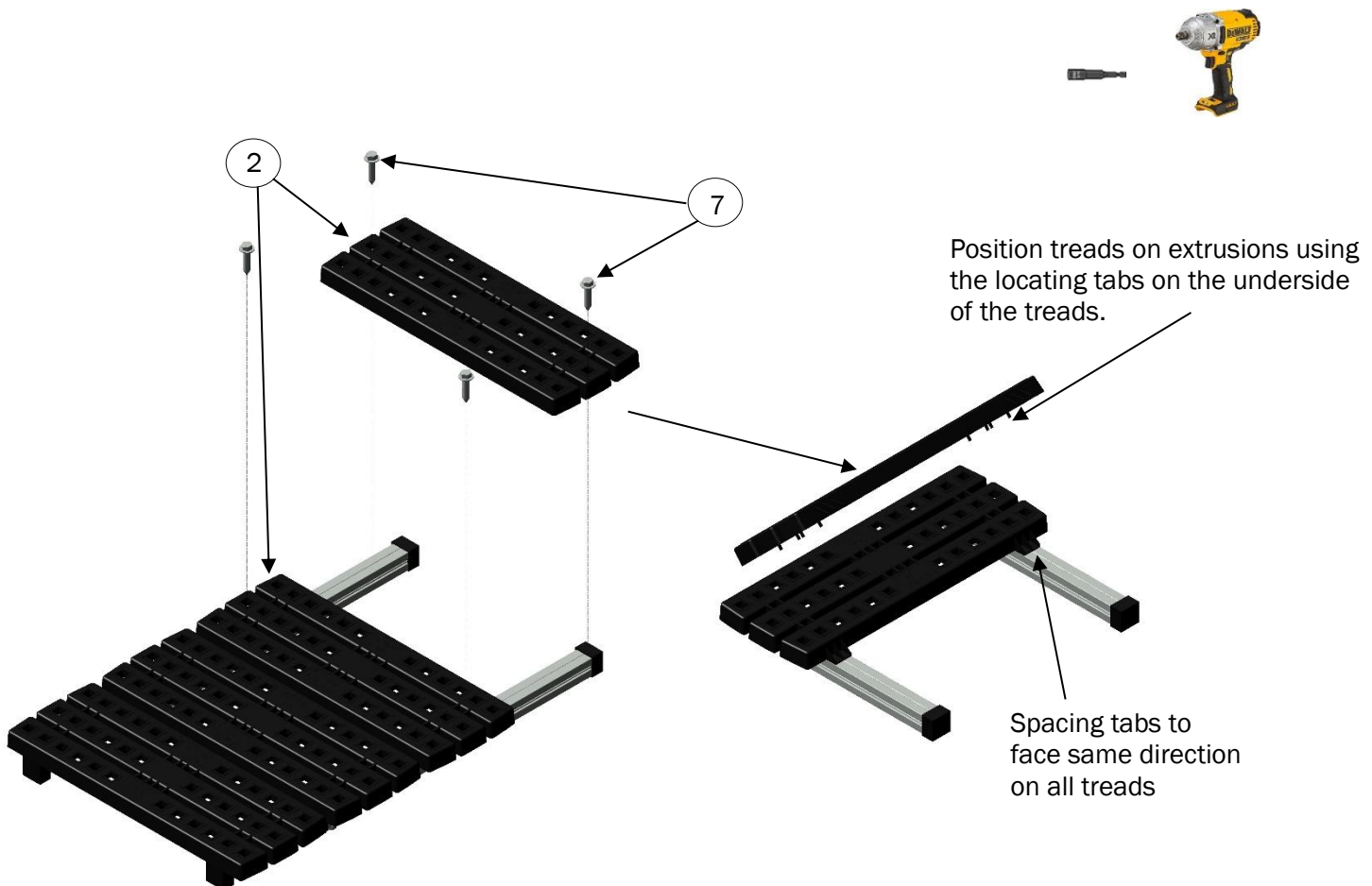

Assembly 3 – Attaching the Support Pipe

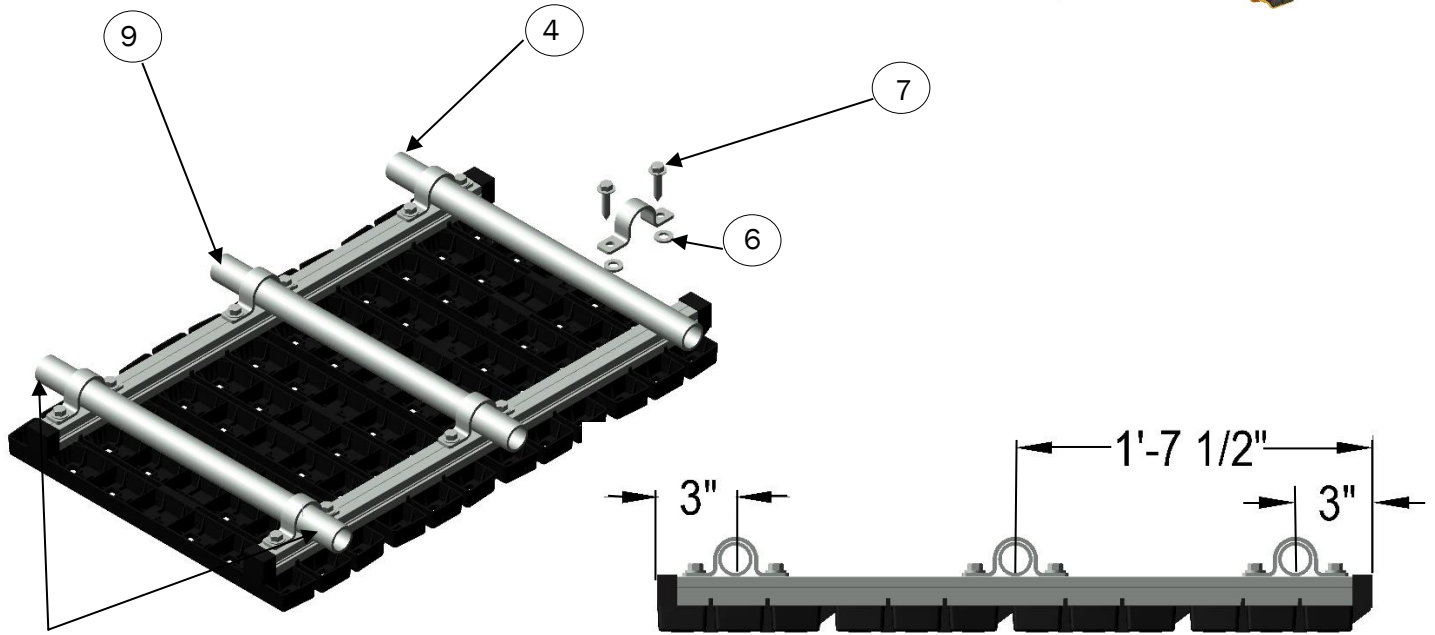

Equal overhang both sides of Extrusion

Assembly 4 – Attaching the Support Pipe to the Stringers

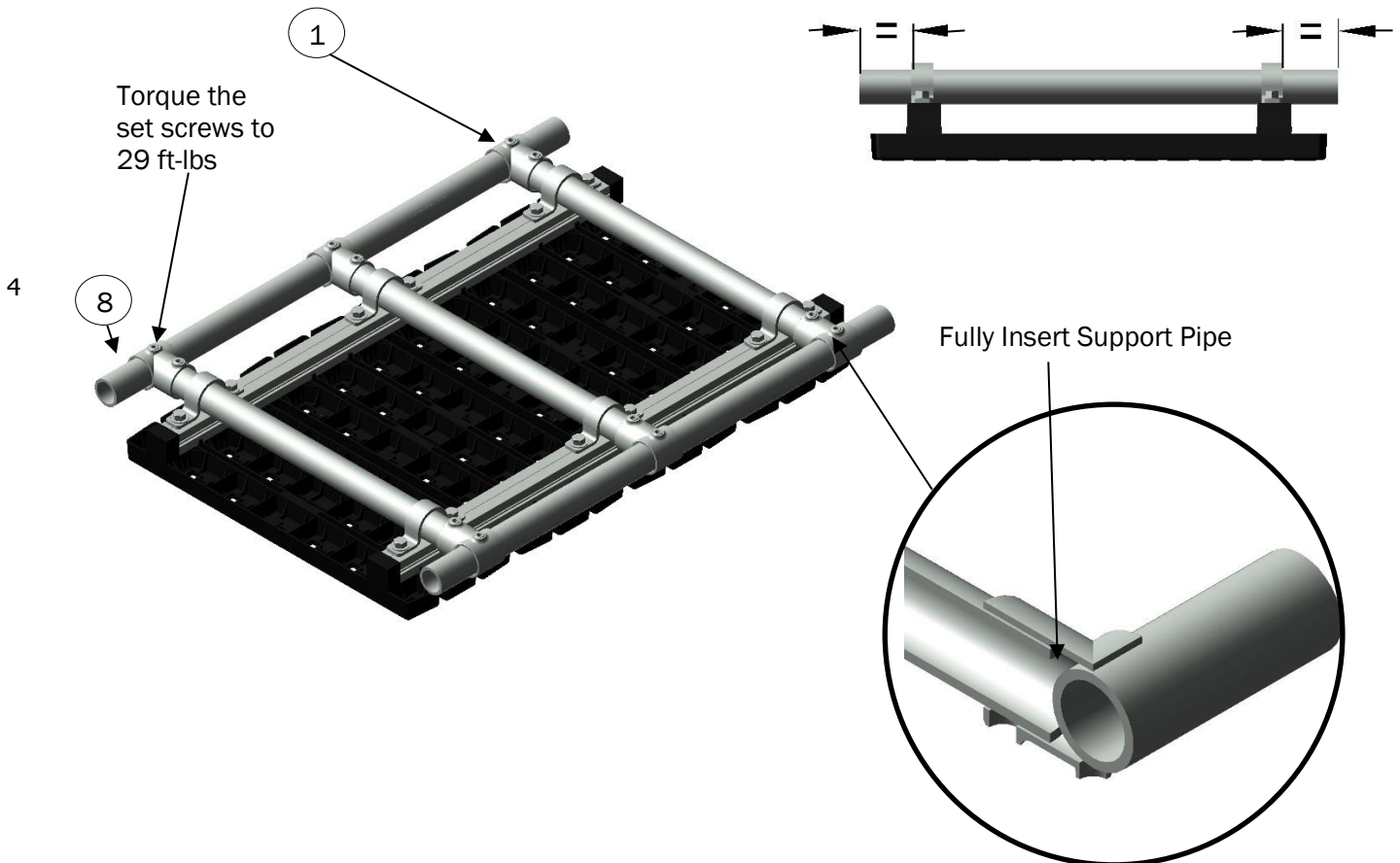

Torque the set screws to 29 ft-lbs

Fully Insert Support Pipe

Assembly 4 – Attach Bridge and rails to the steps

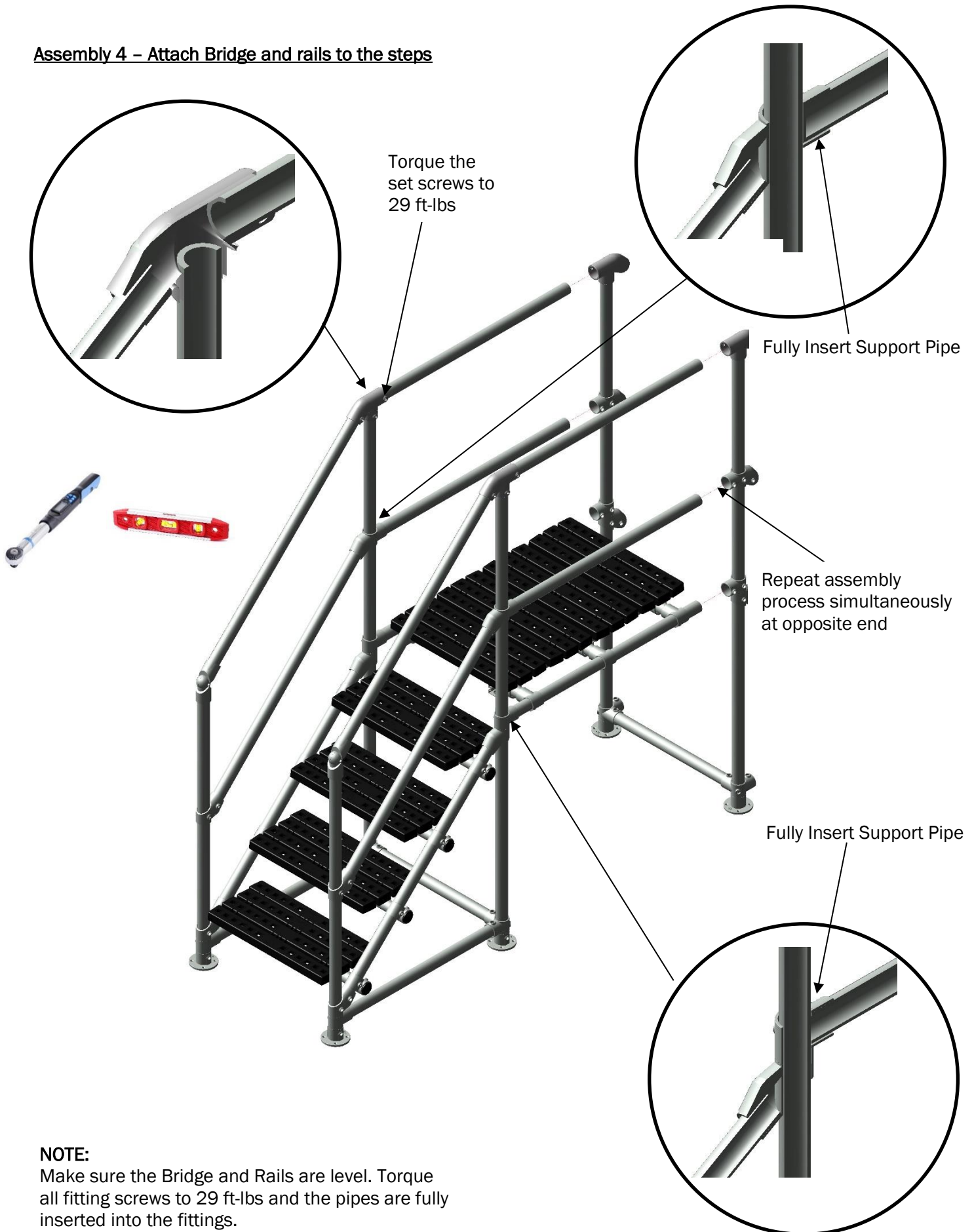



Step Recertification

KEE STEP, SYSTEM RECERTIFICATION

Periodic inspections by a competent person are recommended by the manufacturer. The frequency will depend upon the environment, location and usage but should be at least every 12 months and a visual inspection should be taken before entering the steps.

Walk and visually inspect the complete installed system in relation to the client's general needs. Establish if any modifications and/or additional products are required to reflect any refurbishment requirements or additional plant & equipment which have been installed and require access.

Check installation configuration is complete as per the original installation drawing/plan.

Ensure the system has not been modified or tampered with by unauthorised persons.

Check all base feet are in contact with the roof.

Check all grub screws are in place and correctly torqued.

Check the general height and level of the system including the leg centres and platform overall configuration. (This only tends to be an issue if the system has been tampered with between inspections).

Any galvanised components showing signs of corrosion should be wire brushed thoroughly and galvanised spray/paint applied as appropriate. If rusted significantly, take digital photographs, and include these in the inspection report.

Where applicable check fixings to walls/structures including cat ladder clamps are in place and sufficiently torqued.